

SWITCHING POWER TRANSFORMERS

● DOMESTIC(JAPAN) UL CSA IEC

Switching power transformers provide excellent safety, reliability, and cost performance. These are built to suit a variety of electronics products. The transformers come in three models : the AL regular type, the AS slim type which is restricted to PCB mounting area, and the AF flat type which is suitable for products with height limitations. All types are suitable for pulse power transformers, choke transformers, drive transformers, etc. These transformers meet to UL1446 class 130.

● TYPE EE. EI-AL

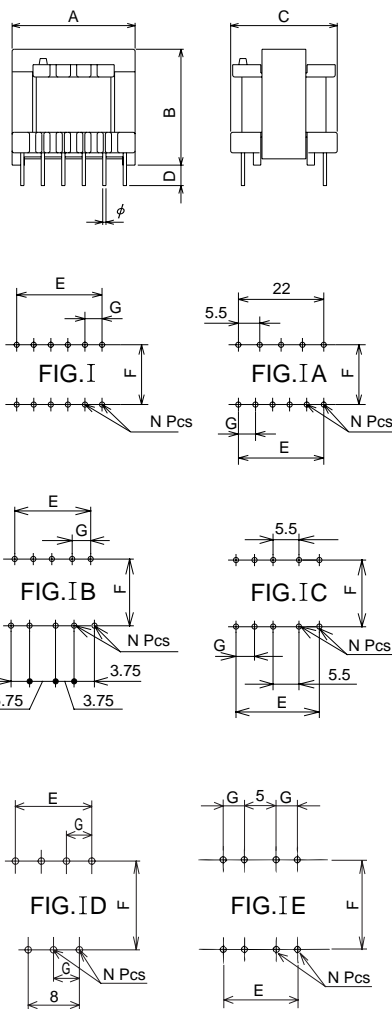
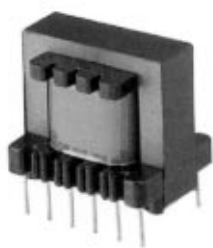

Model	A	B	C	D	E	F	G	ϕ	N	Fig
EE0804	8.7	8.0	8.0	3.0	5.0	6.0	2.5	ϕ 0.42	3-3	I
EE1005	10.5	11.0	10.5	3.0	7.7	8.0	2.6	0.5	4-4	I
EI1205A	13.0	9.5	12.5	3.0	10.0	7.5	2.5	0.6	5-5	I
EE1306	13.5	13.0	13.0	3.0	10.0	8.5	2.5	0.6	5-5	I
EE1605	16.5	14.0	13.0	2.9	6.2	9.2	3.1	0.6	3-3	I
EE1605A	17.0	16.5	13.0	3.6	13.0	10.5	3.25	0.6	5-5	I
EE1607	16.5	15.5	14.0	4.0	13.2	11.0	3.3	0.6	5-5	I
EE1905	19.5	16.5	17.0	3.45	8.0	12.5	4.0	0.6	3-3	I
EE1905A	19.5	17.5	15.0	4.0	15.0	10.0	5.0	0.6	4-4	I
EE1905B	19.5	16.5	15.0	3.5	8.0/12.0	11.0	4.0	0.7	3-4	ID
EE1905C	22.0	18.5	16.0	3.5	16.0/17.0	12.5	4.0	0.7	5-5	IB
EE1905LT	20.5	31.0	17.0	3.5	12.5	12.5	3.75	0.8	4-4	IE
EE2206	22.5	20.5	17.0	3.6	15.0	12.5	5.0	0.8	4-4	I
EE2206A	22.5	19.0	17.0	3.7	16.0	12.0	4.0	0.8	5-5	I
EE2206L	22.5	30.0	17.0	4.0	15.0	12.5	5.0	0.8	4-4	I
EE2206M	22.5	19.0	18.0	3.7	17.5	14.0	4.0	0.8	5-5	IC
EE2507	26.0	20.5	17.5	3.5	15.0	12.5	5.0	0.8	4-4	I
EE2507A	26.5	20.0	19.0	5.2	22.0/22.5	15.6	4.5	0.8	5-6	IA
EE2507T	26.0	21.0	18.0	4.0	20.0	12.5	5.0	0.8	5-5	I
EI3011	31.0	28.0	25.0	7.0	20.0	20.0	5.0	0.8	5-5	I
EI3011A	31.0	28.0	26.0	5.0	25.0	20.0	5.0	0.8	6-6	I
EE3313A	34.0	31.0	28.5	7.0	25.0	22.5	5.0	0.8	6-6	I
EE3313D	34.0	31.0	28.0	3.3	30.0	22.5	5.0	0.8	7-7	I
EE3313E	38.5	33.0	28.5	4.0	35.0	22.5	5.0	0.8	8-8	I
EE3313T	44.0	34.0	28.0	5.0	40.0	22.5	5.0	0.8	9-9	I
EE3510D	38.5	45.0	27.5	4.0	35.0	22.5	5.0	1.0	8-8	I
EI4012	40.5	38.0	28.0	5.0	25.0	22.5	5.0	0.8	6-6	I
EE4012B	43.0	41.0	33.0	4.0	40.0	25.0	5.0	1.0	9-9	I
EI4012C	40.5	37.0	30.0	7.0	25.0	25.0	5.0	1.0	6-6	I
EE4016	43.0	41.0	34.5	4.0	40.0	25.0	5.0	1.0	9-9	I
EE4215	55.0	50.0	35.0	4.0	50.0	25.0	5.0	1.0	11-11	I
EE4220	55.0	50.0	40.0	4.0	50.0	28.0	5.0	1.0	11-11	I
EE4415	45.0	39.0	34.0	4.5	35.0	27.5	5.0	1.0	8-8	I
EI5015	51.0	44.0	36.0	9.0	37.5	27.5	7.5	1.0	6-6	I
E16016	60.5	48.0	45.0	5.0	37.5	35.0	7.5	1.0	6-6	I

KAMI ELECTRONICS IND. CO., LTD.

SWITCHING POWER TRANSFORMERS

● TYPE ER-AS

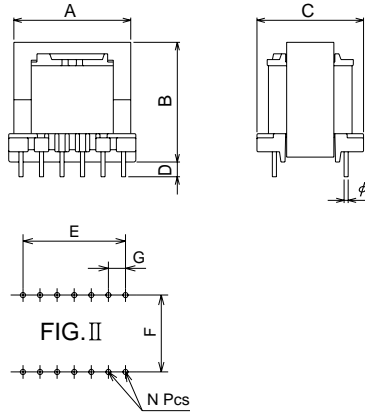

Model	A	B	C	D	E	F	G	ϕ	N	Fig
ER2507T	26.0	21.0	19.6	5.0	15.0	12.5	5.0	0.8	4-4	II
ER2507	26.0	20.5	19.5	3.2	22.5	15.0	3.75	0.8	7-7	II
ER2810SSR	29.0	17.5	23.0	3.6	20.0	17.5	5.0	0.8	5-5	II
ER2810SB	30.0	23.5	25.0	4.5	25.0	17.5	5.0	0.8	6-6	II
ER2810SC	30.0	23.5	25.0	4.5	25.0	20.0	5.0	0.8	6-6	II
ER2810SG	29.0	25.0	22.5	3.5	25.0/24.5	17.5	5.0/3.5	0.8	6-8	II
ER2810SD	30.0	21.5	22.5	4.5	25.0/24.5	17.5	5.0/3.5	0.8	6-8	II
ER2810SE	29.0	22.0	22.5	3.5	20.0	17.5	5.0	0.8	5-5	II
ER2810	31.0	29.0	26.0	3.6	25.0	22.0	5.0	0.8	6-6	II
ER2810T	29.0	30.0	23.0	5.0	20.0	17.5	5.0	0.8	5-5	II
ER2810A	31.0	32.0	25.0	3.5	28.0	20.0	4.0	0.8	8-8	II
ER2810N	31.5	31.5	22.5	3.6	25.0	17.5	5.0	0.8	6-6	II
ER2810LF	29.0	35.0	26.0	3.6	25.0	22.0	5.0	1.0	6-6	II
ER2810TL	29.0	35.0	23.0	5.0	20.0	17.5	5.0	0.8	5-5	II
ER2810LJ	31.5	37.0	22.5	3.6	25.0	17.5	5.0	0.8	6-6	II
ER3510T	36.0	44.0	28.0	5.0	25.0	22.5	5.0	1.0	6-6	II
ER3511A	38.5	48.0	27.5	4.0	35.0	22.5	5.0	1.0	8-8	II
ER3913T	39.0	48.0	29.0	4.0	30.0	25.0	5.0	1.0	7-7	II
ER4014	40.5	48.0	33.0	4.5	35.0	25.0	5.0	1.0	8-8	II
ER4014T	40.5	46.0	30.0	5.0	25.0	25.0	5.0	1.0	6-6	II
ER4215T	43.0	46.0	29.0	5.0	30.0	25.0	5.0	1.0	7-7	II
ER4220T2	44.5	46.0	37.0	5.0	37.5	30.0	7.5	1.0	6-6	II
ER4220T	43.5	46.0	35.0	4.5	30.0	30.0	5.0	1.0	7-7	II
ER4917T	49.5	56.5	37.0	5.0	40.0	28.0	5.0	1.0	9-9	II

● TYPE EE. ER-AF

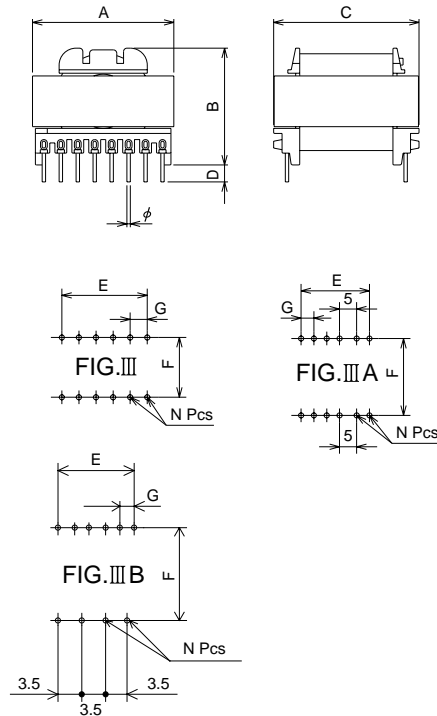

Model	A	B	C	D	E	F	G	ϕ	N	Fig
EE1605T	16.5	13.5	15.0	4.0	9.0	11.0	3.0	0.6	3-3	III
EE1605F	16.5	15.5	26.0	3.5	10.0	22.0	2.5	0.6	5-5	III
EE1605AF	16.5	12.5	15.5	3.5	13.5	12.0	2.7	0.6	4-6	III B
EE1905F	19.5	16.0	16.5	3.5	13.0	12.0	3.25	0.7	5-5	III
EE2206F	24.0	20.0	31.0	3.5	20.0	22.5	3.75	0.8	6-6	III A
ER2409F	29.0	23.0	33.0	3.8	25.0	25.0	5.0	0.8	6-6	III
ER2507F	26.0	18.0	22.0	3.5	20.0	16.0	5.0	0.8	5-5	III
ER2810AF	29.0	26.0	38.0	4.0	25.0	30.0	5.0	0.8	6-6	III
ER2810Z	29.0	24.5	31.0	4.0	25.0	25.0	5.0	0.8	6-6	III
ER3314	36.0	32.0	42.5	3.5	30.0	32.5	5.0	1.0	7-7	III
EE3510DF	40.0	29.0	44.0	4.0	35.0	35.0	5.0	1.0	8-8	III
ER3511F	40.0	29.0	44.0	5.0	35.0	35.0	5.0	1.0	8-8	III
ER3913TF	40.0	33.0	46.0	3.5	35.0	35.0	5.0	1.0	8-8	III
ER4014AF	40.5	33.0	46.0	5.0	35.0	35.0	5.0	1.0	8-8	III
ER4014F	41.0	35.0	45.0	3.0	35.0	35.0	5.0	1.0	8-8	III
ER4216TF	42.5	35.0	45.0	5.0	35.0	35.0	5.0	1.0	8-8	III
ER4917TF	50.5	42.0	60.0	5.0	44.45	50.8	6.35	1.2	8-8	III

SWITCHING POWER TRANSFORMERS

● TYPE EP-AF

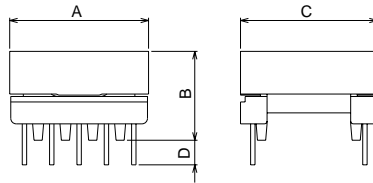

Model	A	B	C	D	E	F	G	ϕ	N	Fig
EP1305T	13.7	8.0	13.7	2.6	10.0	10.5	2.5	0.49	5-5	IV
EP1706T	18.0	12.5	17.5	4.5	12.5	15.0	2.5	0.49	4-6	IVB
EP1906T	19.5	12.0	20.0	4.5	12.5	16.25	2.5	0.49	5-6	IVC
EP2508T	25.5	16.5	25.5	3.5	20.0/18.75	20.0	3.75	0.8	5-6	IVA
EP2708T	27.5	15.5	32.5	5.5	20.0/18.75	27.5	3.75	0.8	5-6	IVA
EP3008T	30.5	16.0	35.5	4.5	25.0	30.0	5.0	1.0	6-6	IV

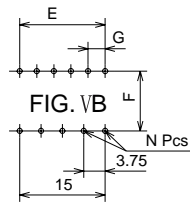
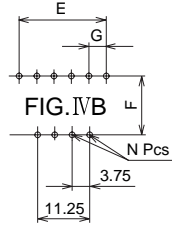
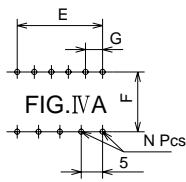
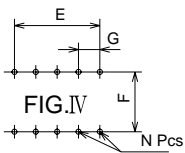

● TYPE EH-AF

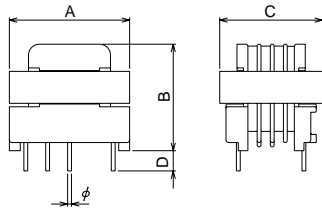

Model	A	B	C	D	E	F	G	ϕ	N	Fig
EH1605	16.5	12.5	15.5	3.5	12.5	12.5	2.5	0.6	6-6	V
EH1906	19.5	11.5	22.0	4.0	12.5	16.5	2.5	0.49	6-6	V
EH2207	22.5	19.5	18.5	3.7	16.0	12.0	4.0	0.7	5-4	VA
EH2508T	25.5	14.0	25.5	3.2	18.75/20.0	20.0	3.75	0.6	6-5	VB

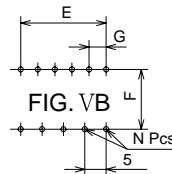
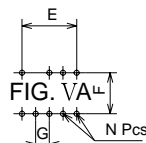
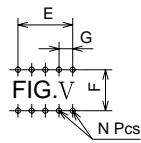

● TYPE SMD

Emboss carrier tape or tray can be prepared for package.

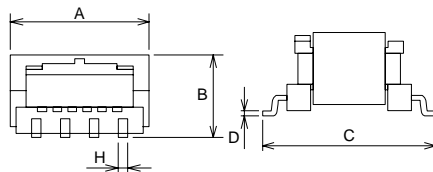

Model	A	B	C	D	E	F	G	H	N	Fig
ER0905	9.5	6.0	11.6	0.3	6.0	11.0	2.0	0.6	4-4	VI
ER1104	11.5	5.5	12.4	0.35	8.0	11.8	2.0	0.52	5-5	VI
ER1105T	11.5	6.5	12.2	0.35	8.0	11.8	2.0	0.52	5-5	VI
ER1406	15.0	7.5	16.0	0.4	10.0	15.3	2.5	0.7	5-5	VI
EP1004AS	11.0	5.5	11.5	0.35	6.0	11.0	2.0	0.52	4-4	VI
EM1203	13.0	6.0	16.7	0.35	6.0	16.2	2.0	0.52	4-4	VI
EM1203A	13.0	6.0	16.7	0.35	8.0	16.2	2.0	0.52	5-5	VI
EP1305AST	14.0	8.5	20.3	0.4	12.0	18.8	3.0	0.6	5-5	VIA
EP1706AS	18.0	11.0	23.0	0.5	14.0	21.8	3.5	1.0	4-5	VIA
EP1906AS	20.0	11.0	25.0	0.5	17.5	23.8	3.5	1.0	4-6	VIB
EP2506	25.5	11.0	28.7	0.4	17.5	27.5	3.5	0.7	5-6	VIC

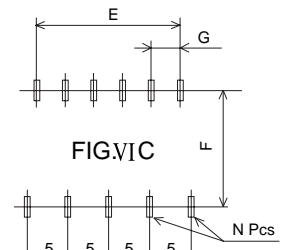
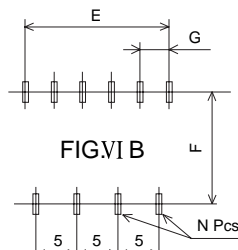
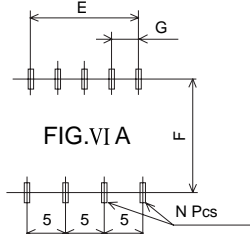
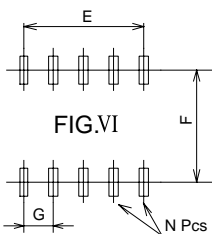

SWITCHING POWER TRANSFORMERS

●TYPE EE-EU

Suit to standard with the new bobbin.
Compact design with triple insulated wire.
Expanding other size now.

EE1605BF

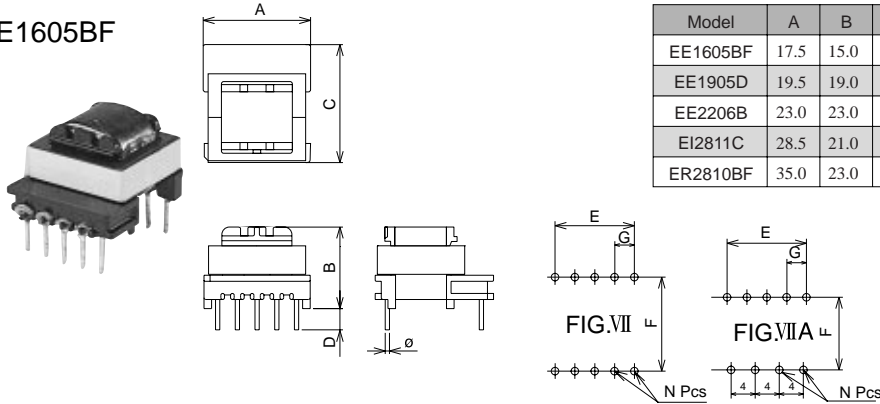

●TYPE EI·ER·ED-INV

This is superior to multi-output and insulation between outputs. It is most suitable for gate drive in inverter control.

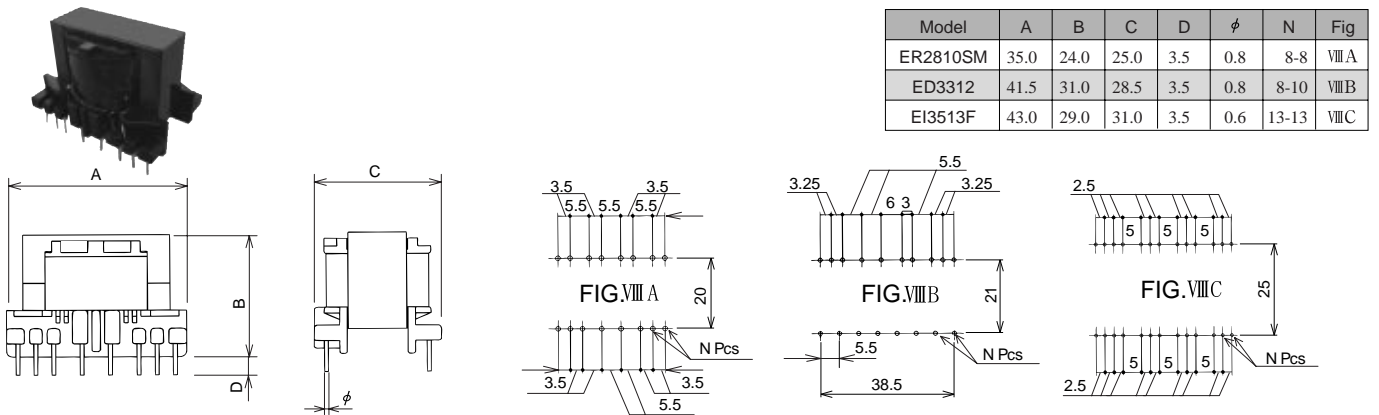

●TYPE PQ

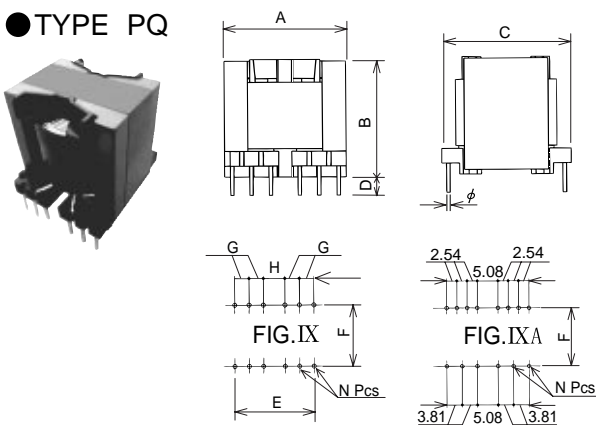

SWITCHING POWER TRANSFORMERS

●TYPE EE-HC

This is choke coil with dust core, which can meet high frequency wave. It is not saturated with instantaneous high current. Compared to ferrite core, the dust core gets more than twice the saturation characteristic (current value). Inductance value can be kept more than half of initial value.

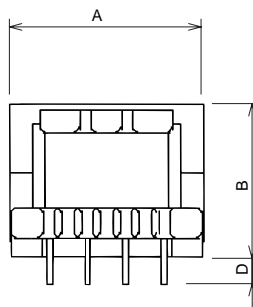
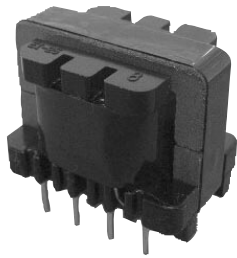

Model	A	B	C	D	E	F	G	ϕ	N
EE2507	26	21	17.5	3.5	15	12.5	5	0.8	4-4
EE2811	27.5	22	23	3.5	20	17.5	5	0.8	5-5
EE3313	35.5	32.5	28	3.3	30	22.5	5	0.8	7-7

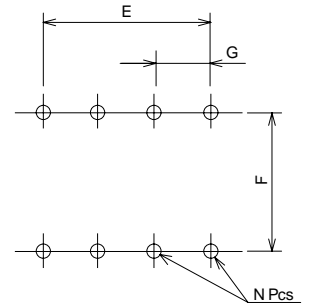
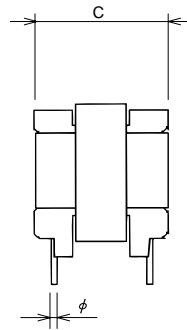

DC SUPERIMPOSITION CHARACTERISTICS FOR EXAMPLE

L-I Characto TYPE:EE3313(at100)

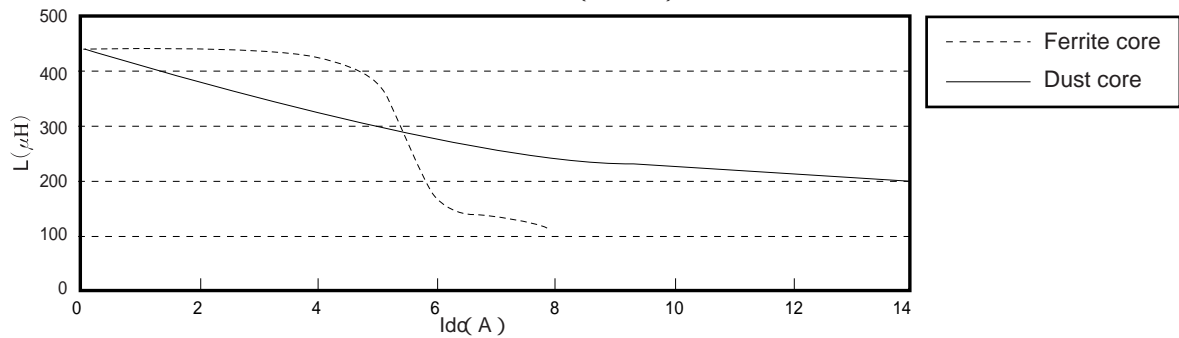

●TYPE EE·ER-HP

Large size transformers for high power.

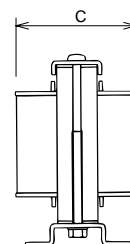
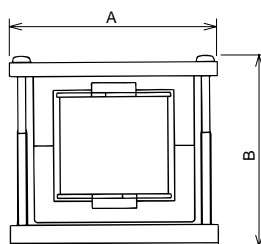

Model	A	B	C
EE8020	105.0	90.0	61.0
ER7016	80.0	86.0	57.0
ER9030	105.0	110.0	77.0